

XS3017S

CONCRETE SPRAYING EQUIPMENT
MANUFACTURED BY XCMG SCHWING

Code: 210706786



Technical Data

Traveling System

Weight	kg	18000
Dimension (L×W×H)	mm	8478×2741×3390
Brand		YuChai
Engine type		YC4DK140-T300
Rated power of engine	kW/rpm	103/2400
Emission standard		Euro 3
Gradeability	%	46
Turning radius	m	7.6
Max. speed	km/h	20
Fuel tank	L	150
Water tank	L	200

Pumping System

Max. theoretical spraying capacity	m ³ /h	30
Pressure on concrete max.	MPa	8
Delivery cylinders	mm	180×1000
Hopper capacity	L	450
Maximum spraying aggregate diameter	mm	22/16
Concrete valve		Rock valve

Note: All data maximum theoretical

Spraying System

Max. spraying height	m	17
Max. spraying width	m	28
Max. front spraying distance	m	14
Min. height for spraying operation	m	4
Max. operation depth	m	7
Axial rotation of nozzle seat	°	360
Axial swing of nozzle seat	°	240
Nozzle brushing along deflection angle X	°	8×360

Additive System

Accelerant agent pump		AFT25
Conveying pressure	MPa	0.8
Accelerant weighing/delivery capacity	L/h	160 ~ 1000

Power System

Electrical appliances type		YE3 250M-4
Electrical appliances power	kW	55
Frequency	Hz	50
Voltage	V	380±5%
Cable length	m	80



Working Range, Dimensions

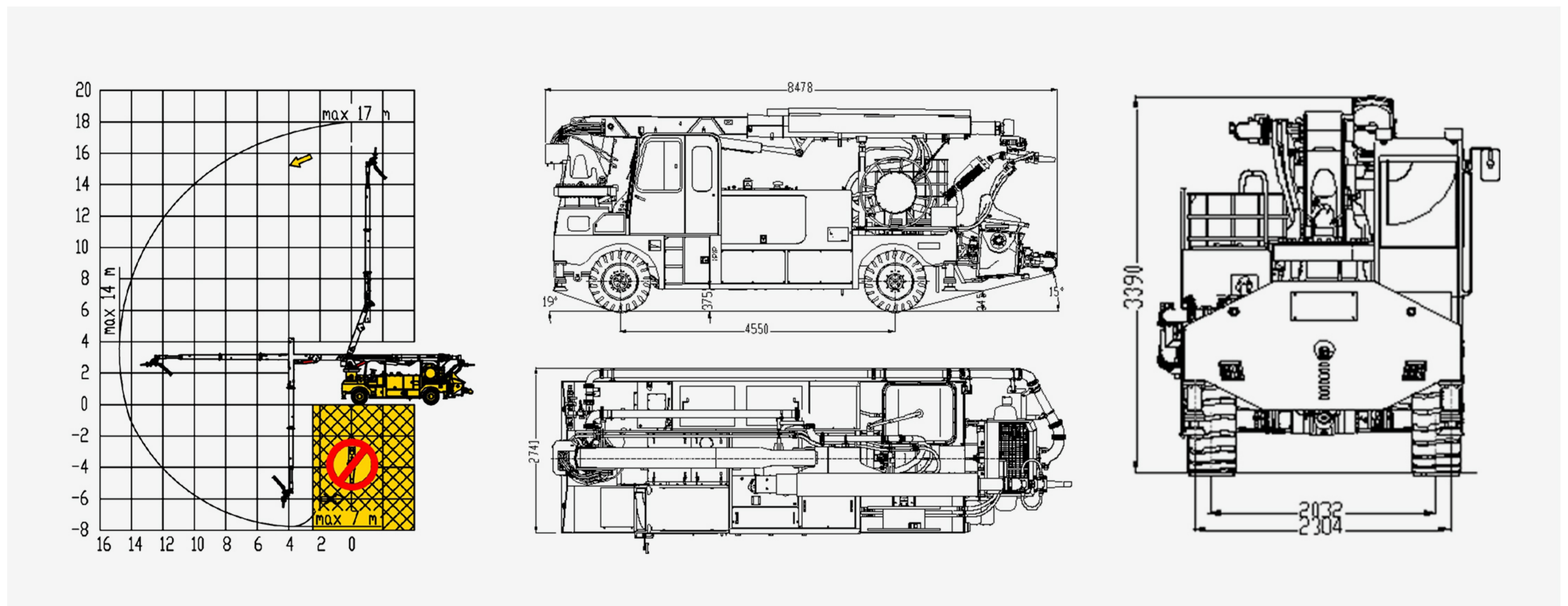

Configuration Features

Overall Structure

- Fully adaptable chassis for all conditions
- Octagonal 2-stage telescopic boom
- Boom key weld joint inspection
- Three-degree freedom spraying mechanism
- Superior spraying volume

Pumping System

- Rock valve pumping technology
- Electric control reversing
- Automatic wear ring compensation
- Piston one-click return

Hydraulic System

- Main valve with SCHWING technology
- Open hydraulic system
- Large displacement hydraulic control cooling system
- Hydraulic system integrated control
- Full-process hydraulic oil filtration

Feeding System

- Streamlined pipeline layout
- Anti-clogging material hopper
- Large-diameter climbing pipe
- Large-angle conveying pipe elbow

Control System

- Integration of SCHWING 's intelligent control technology
- Boom limit technology
- Automatic proportioning technology of accelerant agent

Others

- Dual lubrication of hydraulic oil and grease
- Strong emergency capabilities of dual-power system
- Outlet pressure of water gun: 7MPa
- Air compressor
- Standard enclosed cab
- Additive system

Add: No.29 Taoshan Road, Economic development zone of Jinshanqiao, xuzhou, Jiangsu Province, China | Tel: +86-516-83111590 | E-mail: xsg@xcmg.com
Right to make amendments reserved | by XCMG SCHWING | All rights reserved



UNITED HEAVY EQUIPMENT & EARTH MOVERS PVT. LTD.

VOITH Complex | Ananda Nagar, Dhumbarahi, Nepal
Tel.: +977 01 4542901-05, Cell : +977 98512 17690
Fax : +977 01 4008813, P.O. Box: 233/2640
Email: info@uheem.com.np, Web: www.uheem.com.np