

# SLM4

**SELF-LOADING CONCRETE TRUCK MIXER  
MANUFACTURED BY XCMG SCHWING**

Code: 210503317



## Technical Data

### Overall parameters

Agitating capacity	m <sup>3</sup>	4
Dimension (bucket lift)	mm	6790 × 2960 × 4450
Dimension (bucket level)	mm	8370 × 2960 × 3450
Weight	kg	9700
Wheelbase	mm	3300
Maximum speed	km/h	30
Gradeability	°	22

### Agitating device

Drum dimensions	mm	1770 × 3390
Drum geometric volume	m <sup>3</sup>	6
Drum installation angle	°	16
Drum wall thickness	mm	4
Blade thickness	mm	4
Drum lifting angle	°	15
Drum rotation angle	°	270

### Drive system

Engine brand	/	Yuchai Power
Engine model	/	YCD4J22T-125
Engine emissions	/	China II
Engine power	kw	92
Gearbox model	/	YJ315
Rated input speed	r/min	2400
Rated input power	kw	74-85
Ultimate input torque	N · m	650

### Traveling system

Drive type	/	Four-wheel drive
Turning form	/	Articulated steering
Braking form	/	Dry brake
Tire model	/	12R22.5
Number of tires	/	Front: 4, rear: 2

### Bucket device

Bucket capacity	L	700
Material door opening method	/	Oil cylinder opening
Bucket vibration motor	/	Standard configuration

### Waterway system

Water tank capacity	L	850
Water metering method	Electronic flowmeter/time controller	
Water tank filling method	Self-priming pump	
Drum water filling method	priming pump/electric motor pump	
High-pressure washing	Standard configuration	

### Others

Hydraulic oil tank capacity	L	75
Diesel tank capacity	L	75
Centralized lubrication	/	Standard configuration
Cab air conditioning	/	Standard configuration
Weighing system	/	Standard configuration
Monitoring system	3-camera system + 10.1-inch display screen	

Note: All data maximum theoretical



## Working Range, Dimensions

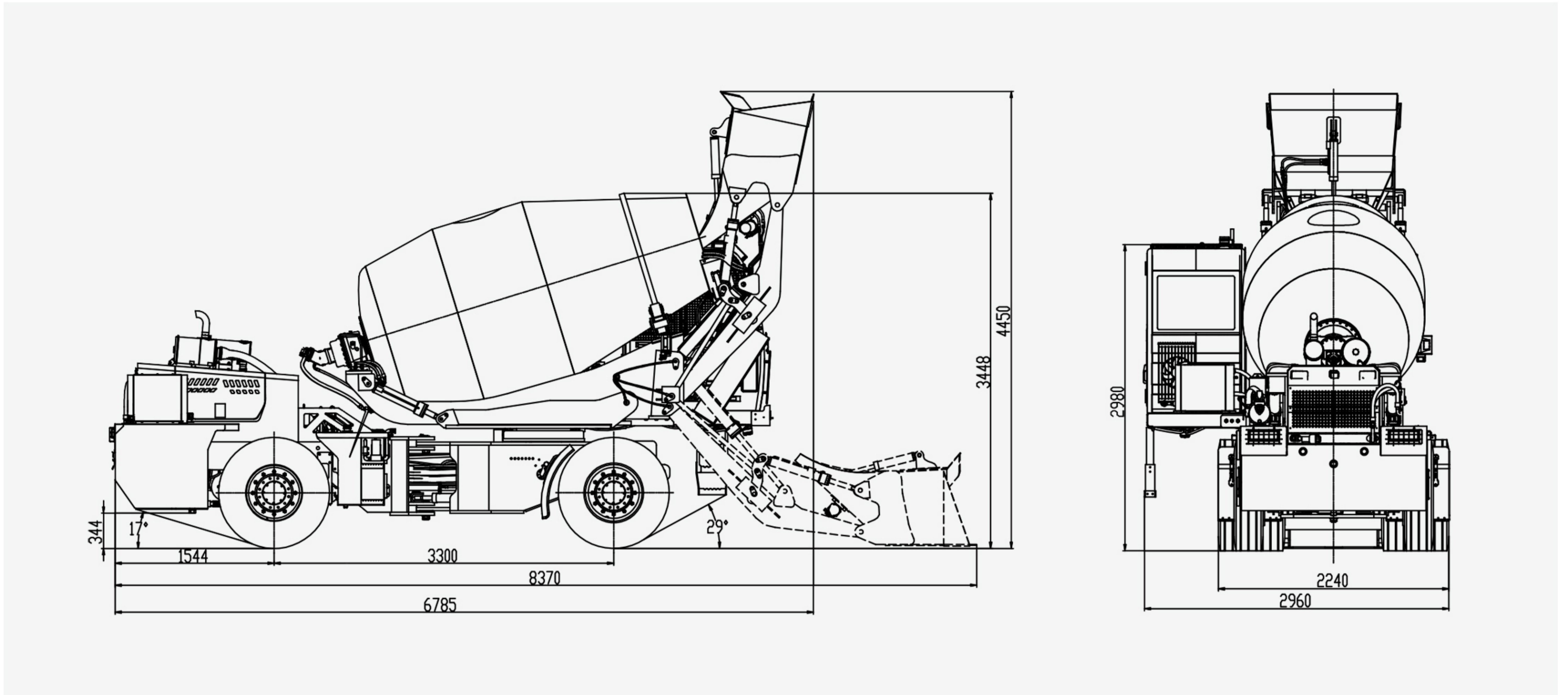

## Configuration Features

### Overall structure

- Split structure design
- Synchronized rotation of cab and mixing drum achieves
- Rear axle swing-type structure design

### Hydraulic system

- Major brand pump, motor and gear reducer
- Proportional control hydraulic valves
- Adapted cooling devices

### Agitating device

- Standard equipped aggregate weighing device
- Drum lifting design
- Continuous trace design for the mixing drum

### Drive and traveling system

- High-power engine + hydraulic torque converter
- 4-wheel drive + articulated steering
- 4 front + 2 rear tires

### Waterway system

- Large-capacity water tank
- Electric motor and hydraulic dual circuit water pump
- Standard equipped water metering device

### User-friendly design

- Reverse camera + blind spot monitoring
- Cab equipped with air conditioning and ratio printer
- hydraulic lifting chute and bucket vibration motor

Add: No.29 Taoshan Road, Economic development zone of Jinshanqiao, xuzhou, Jiangsu Province, China | Tel: +86-516-83111590 | E-mail: xsg@xcmg.com  
Right to make amendments reserved | by XCMG SCHWING | All rights reserved



## UNITED HEAVY EQUIPMENT & EARTH MOVERS PVT. LTD.

VOITH Complex | Ananda Nagar, Dhumbrahi, Nepal  
Tel.: +977 01 4542901-05, Cell : +977 98512 17690  
Fax : +977 01 4008813, P.O. Box: 233/2640  
Email: info@uheem.com.np, Web: www.uheem.com.np